

# Did YOU KNOW

#2019-007

DATE LAST REVISED  
02 AUG 2019

Written By: Doug Perry

**Question:** What factors go into selecting regulator gauges?

## Answer:

**FIRST, TO FULLY UNDERSTAND AND ANSWER THE QUESTION WE MUST CLARIFY THE DIFFERENCE BETWEEN A REGULATOR AND A GAUGE. OFTEN, AND MISTAKENLY, A REGULATOR IS REFERRED TO AS A “GAUGE” OR “SET OF GAUGES”.** The truth is a regulator is a device whose function is to take an unusable high pressure from a gas cylinder or pipeline and convert it into a usable, safe, and constant lower pressure. A gauge is a simpler device whose function is only to indicate and read-out either or both high and low pressures that, in this case, are flowing through the regulator. Cylinder regulators typically have two gauges: a high-pressure or “inlet” gauge, and a low-pressure “outlet” or “delivery gauge”.

## SELECTING THE RIGHT GAUGE

Gauges are selected for a regulator or other applications, considering the regulators intended supply or inlet pressure and designed outlet pressure. Two of the major considerations are accuracy and safety.

**Accuracy:** Virtually all applications using gases require some degree of accuracy to ensure proper and safe performance. A common comparison would be the accuracy a driver would demand from the speedometer in an automobile he or she was operating. In the industrial or welding gas industry we look to an accuracy like that suggested by the Compressed Gas Association (CGA) in their E-4 standard for gas pressure regulators. In standard gauges most commonly used in our industry, Grade B are accurate within 2% - 3% of the gauge span or gauge face reading, depending somewhat where on the gauge face the pressure is read. See the drawing example using a 100 PSIG gauge.

**Safety:** There are an innumerable number of choices in our industry of gauge pressure ranges to choose from when selecting a gauge for a regulator or other use. The trick is to choose a gauge that provides the reading accuracy required while still providing durable and safe operation. Again, referring to standards like CGA E-4 1994 (5.7.2) we select gauges so that the maximum operating pressure to which they would normally be exposed in service is not greater than 80% of the gauge range. We also take into consideration all other factors that may affect pressures such as those related to temperature, gas mode, etc.

## THE “CENTER HALF RULE”

A good rule of thumb to use when selecting a regulator, and in this case a particular gauge for a gas application requiring a specific pressure, is to select one that will read the pressure required in the center half of the gauge range but not disregarding hazards such as those associated with over pressurization.

Pressure gauges shall be of accuracy Grade B or better (+/- 3%, 2%, 3% of range or span) as specified in ANSI B40.1.

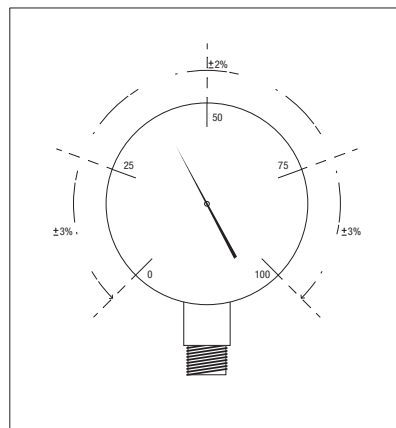

## EXAMPLE:

Accuracy of a typical 100 PSIG gauge reading

- @ 0-25 PSI: +/- 3 PSI
- @ 26-75 PSI: +/- 2 PSI
- @ 51-100 PSI: +/- 3 PSI

Minimum gauge size for  
Grade B accuracy – ½” 270° dial arc

Turn to the  
**Pros**



FOR MORE INFO ABOUT GAUGES

Email our Customer Service group at  
custservmason@jwharris.com  
or call - 1.800.733.4043.